

RS-NAGU.12

Operating instructions for muting controller RS-NAGU.12 category 2 / PL e (EN ISO 13849-1) with semiconductor outputs in combination with a category 2 ESPE with 2 outputs (PNP or relay)

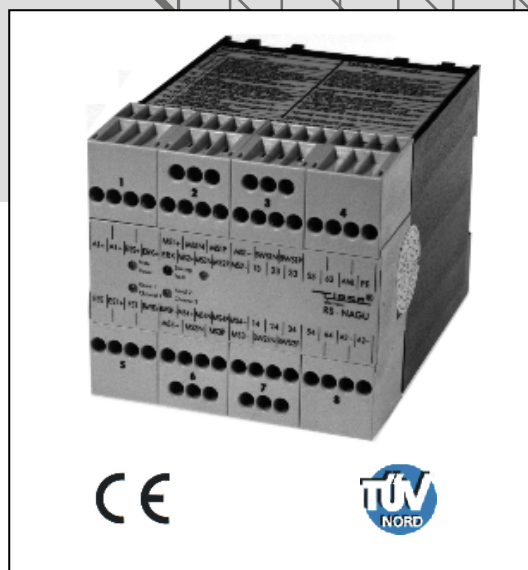
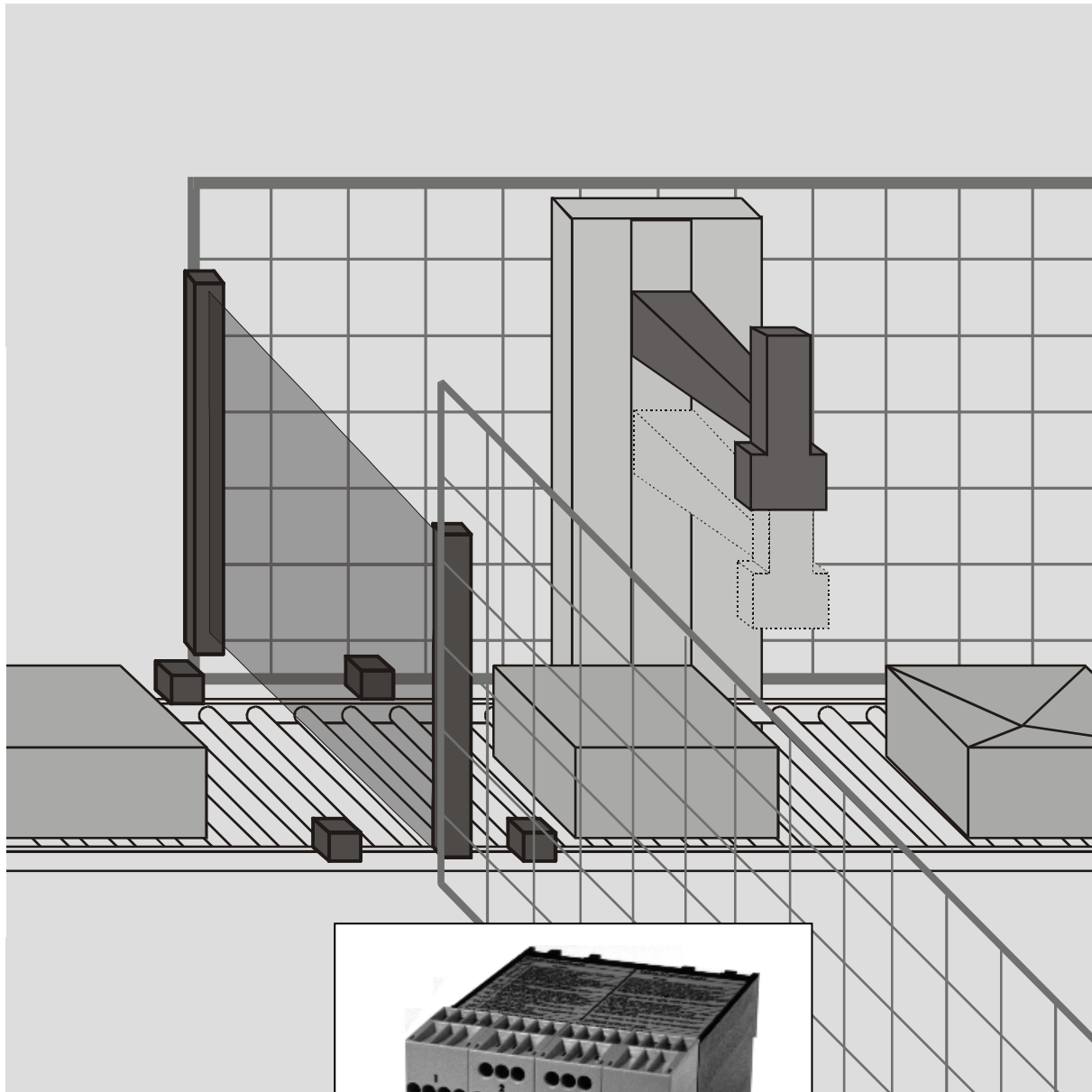

Introduction

These operating instructions should familiarize you with the muting controller RS-NAGU.12 for category 2 (EN ISO 13849-1). The following pages contain information about:

- Structure and function
- Assembly
- Electrical installation
- Maintenance and repair
- Possible failures and actions to rectify failures

Target audience

These operating instructions are intended for the following persons:

- Skilled personnel who plan or develop safety equipment for machines and plants and are familiar with the safety instructions and safety regulations.
- Skilled personnel who build in safety equipment into machines and plants and activate them.

Guide to symbols

The operating instruction contains several symbols which are used to high-light important information:



This symbol show text passages which should absolutely payed attention too. Non-observance leads to serious injuries or damage to property.



This symbol show text passages which contain important information.



This sign is placed for activities.



This sign shows a description how the condition has changed after an activity has been carried out.



This symbol marks the transmitter of a safety light barrier / -grid.



This symbol marks the receiver of a safety light barrier / -grid.

Explanation of terms

BWS = ESPE	<u>E</u> lectro <u>s</u> ensitive <u>p</u> rotective <u>e</u> quipment include light barriers, light curtains and light grids
Muting	Temporary bypassing of a ESPE in order to transport material into or out of the danger area.
Restart inhibit	Prevention of automatic restart of the machine.

List of contents

Safety instructions_____	page 3
Application and function_____	page 4
Muting components and function_____	page 6
Installation and implementing_____	page 8
Usage as a controller for safety light barriers_____	page 13
Maintenance and repair_____	page 14
Troubleshooting_____	page 14
Technical data _____	page 16

Safety instructions

Intended use

The muting controller RS-NAGU.12 is used in conjunction with safety light barriers or safety light grids to safeguard danger areas and hazard points. The integrated muting function permits goods to be transported into or out of the danger area without impairment to the safety function of the equipment.



The RS-NAGU.12 may also be used as a controller for safety light barriers.



Please note the wiring instructions for this operating mode on page 13.

WARNING

The safety of persons and equipment cannot be guaranteed if the muting controller is not used in accordance with its intended use.

For your safety

WARNING

Observe the following points without fail:

- **The device may only be build in and operated by specialized staff, who are familiar with this instruction and the current regulations for safety at work and accident prevention. Working on electrical equipment is only allowed for specialized staff.**
 - **Any repairs have to be done by the manufacturer or a person which is authorized by the manufacturer. It is prohibited to open the device or implement unauthorized changes, otherwise any warranty expires.**
 - **Pay attention to valid regulations, particularly in reference to preventative measures and the installation of muting sensors, the muting lamp and the BWS.**
 - **The danger area must be observable by the assembling area of the start button.**
 - **It must be impossible to start the equipment from the danger area.**
 - **Avoid mechanical vibration and impacts during transport and operation. Impacts greater than 0.7 Nm or vibrations with a frequency > 33 Hz or an amplitude > 0.35 mm can lead to damage of the equipment.**
 - **The device must only supplied by a SELV- or PELV-power supply**
-

Application and function

Introduction

The muting controller RS-NAGU.12 is used in conjunction with safety light barriers or safety light grids to safeguard danger areas and danger points up to safety category 2 to EN 954-1. The integrated muting function to EN 61496 permits goods to be transported into or out of the danger area without impairment to the safety function.

The device is suitable and tested for connection to safety light barriers and light grids from a wide range of different manufacturers. A current list of tested light grids / light barriers and the relevant wiring instructions are provided in the "Applications" brochure. If you didn't find the safety light barrier or safety light grid you wish to use in this list, please contact us by telephone or mail.

The diagram below provides an initial impression of connection possibilities. In the section "Installation and commissioning", step-by-step instructions are provided on electrical connection of the muting controller.

The testing of the ESPD must be done by the ESPD.

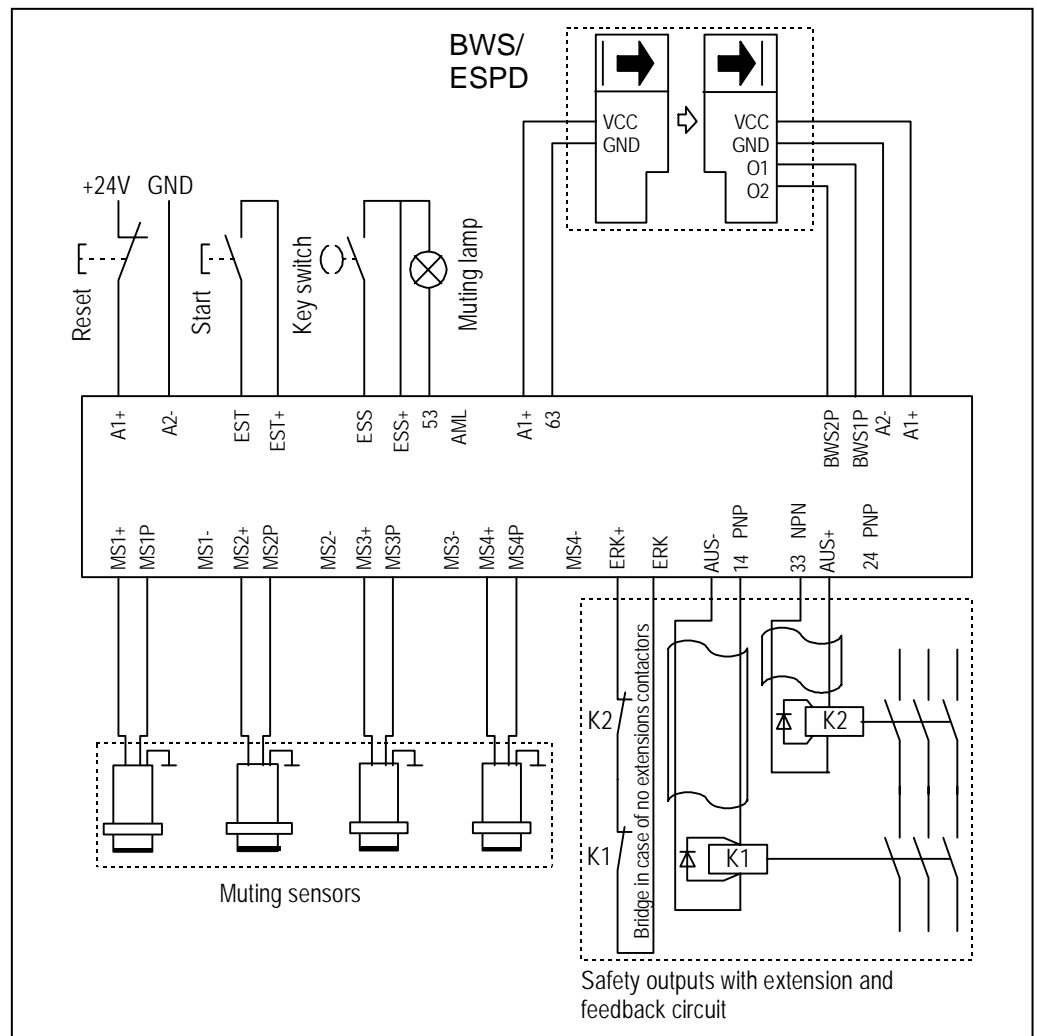

Outputs

The safety outputs are non-wearing PNP (2) and NPN (1) solid-state outputs.

Display

Five LEDs are used to indicate status.

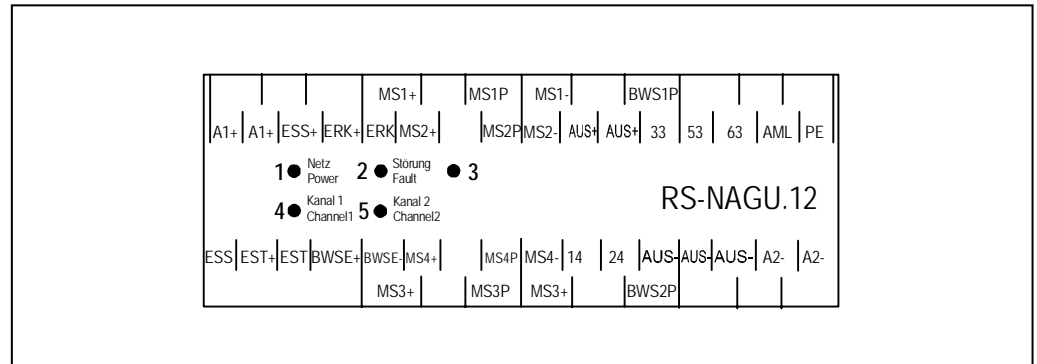

- 1** Power ON
- 2** Fault
- 3** Restart inhibit on, waiting for start
- 4** Operation – Channel 1 activated
- 5** Operation – Channel 2 activated
- 4+5 flashing** Error code

Function

After applying the supply voltage, the device performs a self test. LEDs 1,3,4 and 5 light up and the device can be activated by pressing the start button.

If the self-test has not been successfully executed, there is a fault or a connection error. For details, see the section "Troubleshooting" on page 15.

If it's not possible to start the device by pressing the start button, at least one of the muting sensors is blocked or incorrectly connected. In the case of blocked muting sensors, see the section "Muting components and function".

Muting components and function

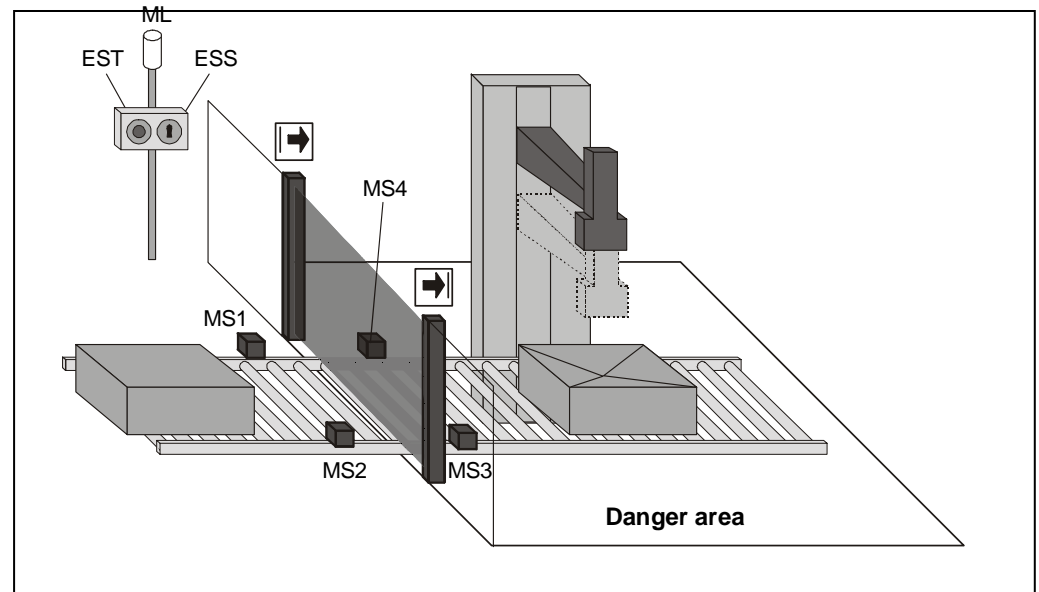

MS1, MS2, MS3, MS4 Muting sensors ML Muting lamp
EST Start button ESS Key-operated switch

Muting

Muting is a temporary, automatic and reliable way of bypassing a presence-sensing safeguarding device (BWS), in order to transport material into or out of a danger area. For this purpose, two or four muting sensors (MS 1-4) are installed at the entrance/exit of the danger area in such a way that only the material activates the sensors. The muting controller then initiates the muting cycle for the period during which the material is being transported through the protected field. It is not possible for a person to activate the muting sensors in the same way. A person approaching the danger area will trigger a shut-down of the hazardous movement.

Muting lamp

During material transport through the protected field, the muting controller switches the muting lamp (ML) on. The muting controller monitors the filament of the muting lamp even when the muting function has not yet been initiated. If the filament is defective, or if no lamp is connected, the muting controller indicates a failure and the safety outputs are switched off.



In accordance with EN 61496-1, the following conditions must be adhered to by the muting lamp. The luminous surface must be at least 1cm² and have a brightness of at least 200cd/m².

Key-operated switch

On start-up of the ESPE using the start key (EST), the muting controller checks whether all the muting sensors are inactive. If this is not the case, for example after a fault in which the material is already located in the area monitored by the muting sensors, the output signals of the muting controller are not switched, in other words the plant comes to a standstill. Using the key-operated switch, the muting cycle can be started and the material can continue to be transported. The muting cycle remains active as long as the key-operated switch is actuated, but for a maximum of ten minutes.

If all muting sensors are subsequently free, the enable circuits and the muting lamp switch off.



Release the key-operated switch and press the start key.

If the key-operated switch is released prematurely, the enable circuits switch off and the muting lamp remains alight.



Press the key-operated switch again.

Muting sensors

Mechanical, inductive, capacitive and opto-electronic sensors are suitable as muting sensors, whereby both sensors with solid-state outputs and also with relay outputs can be used. If retroreflective light barriers are used as muting sensors, they are arranged across corners. The cross-over point of the light beams must be located behind the safety light barriers in the danger area.

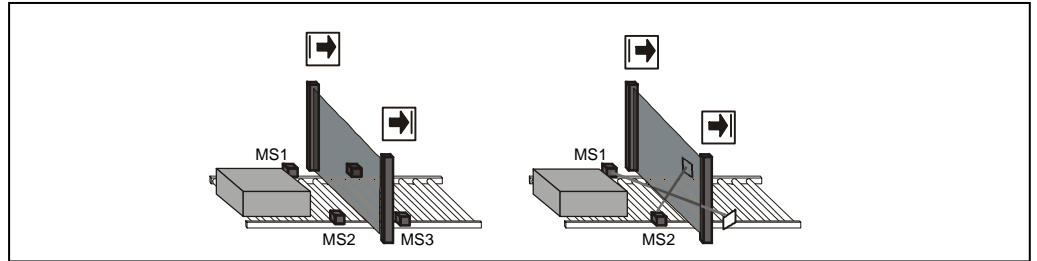

1. The muting sensors must have a rated voltage of 24 V DC at the output.
2. Only light barriers with a dark switching output can be connected to the muting controller as muting sensors.

Sequence of a muting cycle

If the muting sensors MS1 and MS2 are activated within 3 seconds, the muting cycle is initiated. The muting lamp is switched on and interruption of the safety light barrier does not cause the device to switch off. If three of the four muting sensors are inactive, the muting cycle is terminated after a delay period of 0.25 seconds.

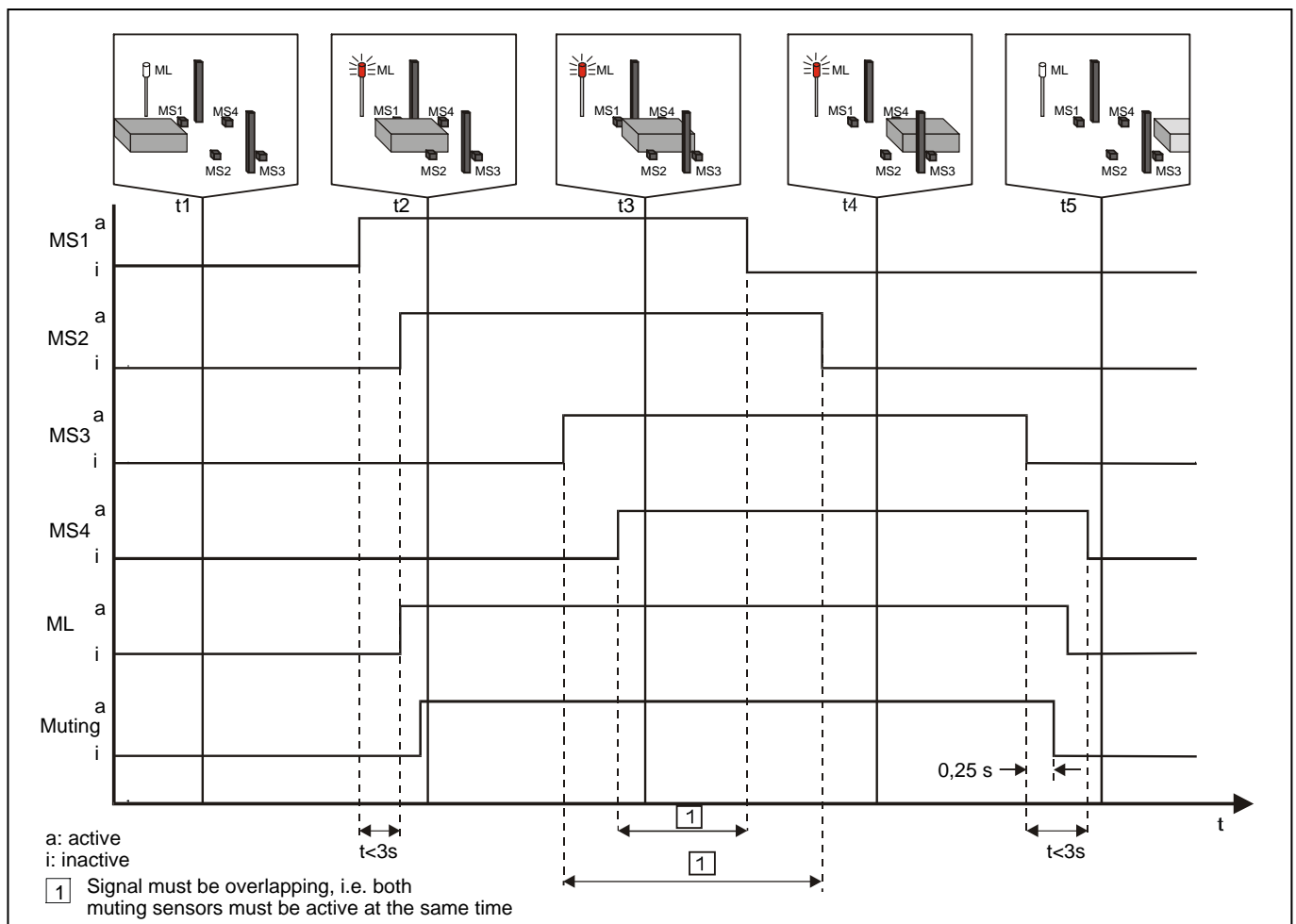

Installation and implementing

WARNING

Dust and moisture can lead to malfunctions. Install the device in a dust and damp-proof housing, for example in a switch cabinet or a IP54 housing.

Mechanical installation

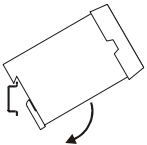

Mount the muting controller on a universal mounting rail.

WARNING

Short circuits, broken cables, power failure or voltage fluctuations in the network can impair and/or cancel the safety function and result in serious accidents.

Pay attention to the following points:

- The safety solid-state output lines and the lines of the two muting sensor groups must be lay in separate non-metallic-sheathed cables.
 - When using two light barriers as muting sensors, the voltage supply for the transmitters must be lay separately and wired separately to the terminals.
 - No circuits may be used which generate a muting signal in case of a cable breakage or power failure.
 - The power supply to the device and all connections must be reliably isolated from the light / threephase mains, either by using an isolating transformer in accordance with IEC 60742 or an equivalent disconnecting device.
-

Electrical connection

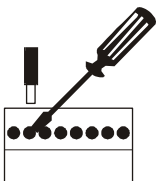

Wiring of the muting controller is subdivided into two areas:

1. General wiring
2. Specific wiring according to the ESPE (BWS) type used

All steps for general wiring are described in the following. A precise description of the specific wiring is provided in the separate brochure "Applications".

Terminals

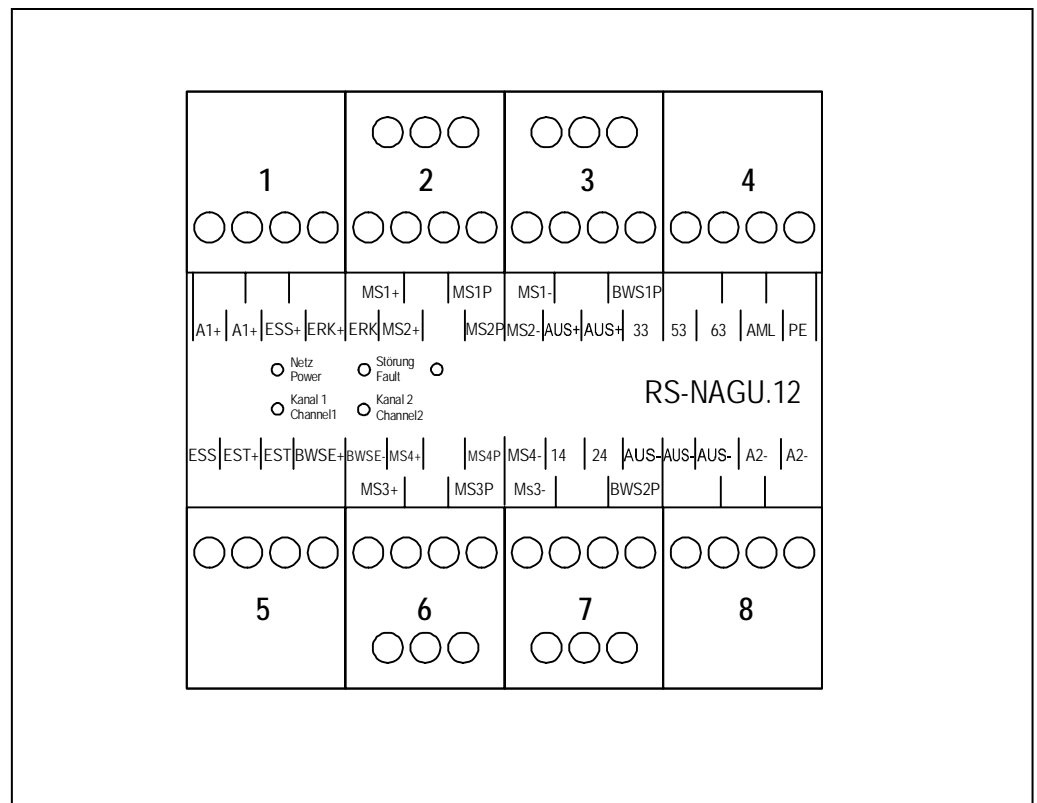

Pins	Meaning
A1+ , A2-	Connection of supply voltage
EST+ , EST	Start button
ESS+ , ESS	Key-operated switch
ESS+ , 53	Muting lamp
AML , 53	Bridge if RS-NAGU.12 is used as a controller for safety light barriers
ERK+ , ERK	Feedback circuit
MSx+	Positive voltage for muting sensor x
MSx-	Negative voltage for muting sensor x
MSxP	Input of muting sensor x -PNP
BWSE+	Positive voltage for BWS signals
BWSE-	Negative voltage for BWS signals
BWSxP	Input of BWS channel x - PNP
14,24	Safety outputs PNP
33	Safety output PNP
63	Safety output NPN
AUS+	NPN output for activating the BWS
AUS-	Positive internal supply voltage (internally connected to EST+ , ESS+ , ERK+ , BWSE+ , MSx+)
	Negative internal supply voltage (internally connected to BWSE- , MSx-)

Wiring

- Supply voltage
- Key-operated switch
- Muting lamp
- Start button

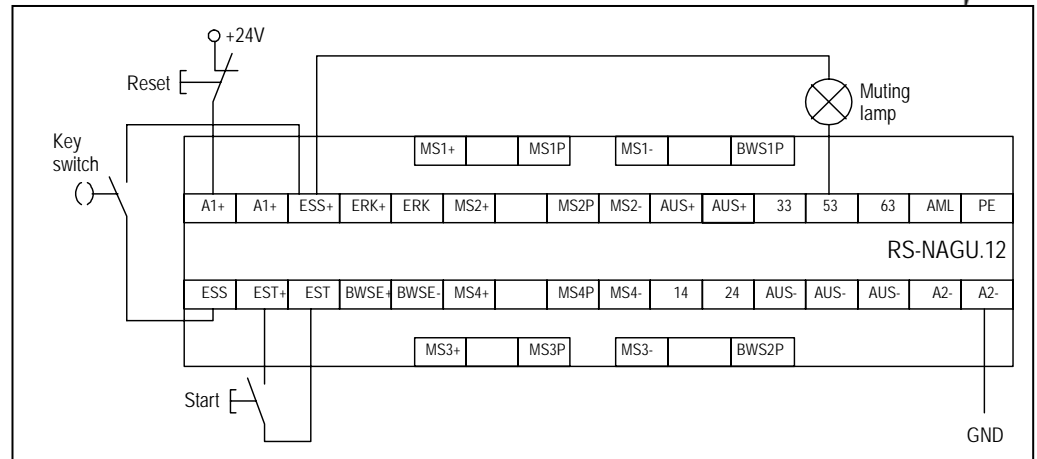

- Connect the key-operated switch to terminals ESS+ and ESS.
- Connect the muting lamp to terminals ESS+ and 53.
- Connect the start button to terminals EST+ and EST.



- Only connect the operating voltage to terminals A1+ and A2- when the remaining wiring has been completely connected.**

Wiring muting sensors

Muting sensors are wired depending on the operating mode, type and number of sensors. Either 2 or 4 muting sensors must be connected to the muting controller. When using two muting sensors, these must be connected to terminals MS1... and MS2... .

- Connect the muting sensors in accordance with the instructions below.

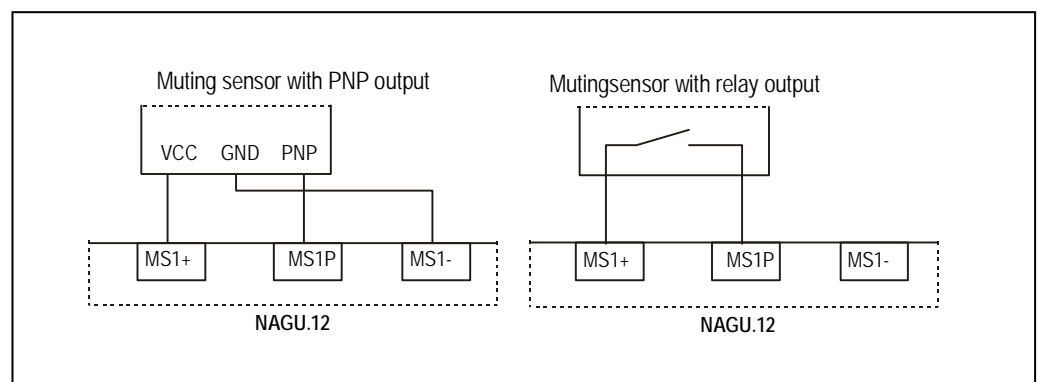

1. If 4 muting sensors are connected, sensors with the same polarity must be used at the terminals MS1.. and MS4.. / at MS2.. and MS3.. .
2. The terminals for MS1../MS4.. and MS2../MS3.. must be laid in separate conted cables.

Wiring ESPE

The precise wiring of the ESPE (BWS) depends on the type and manufacturer. In general, however, the following wiring rules apply:

1. Connect the outputs at the ESPE (BWS)



Connect the outputs of the BWS receiver directly to the inputs of the muting controller (BWS1P and BWS2P) .

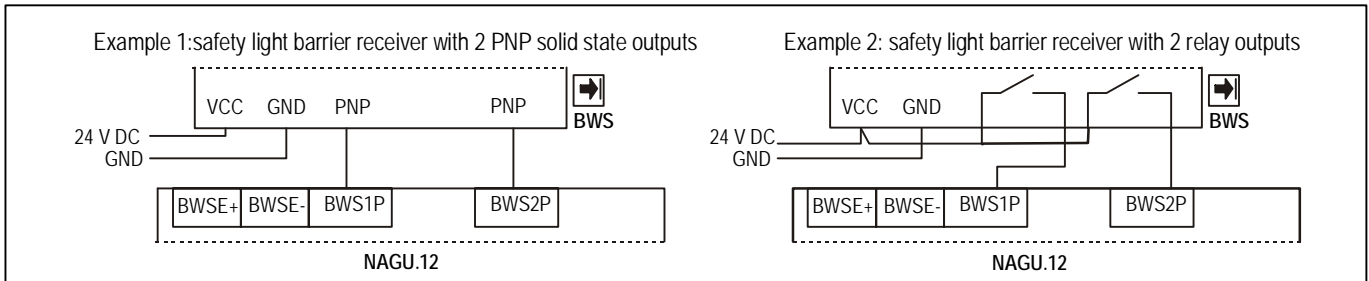

In the case of safety light barriers / light grids with solid-state outputs, the light switching outputs must be used.

2. Connect the operating voltage



Connect the ESPE (BWS) receiver directly to the external power supply.



Connect the ESPE (BWS) transmitter to the muting controller in accordance with the instructions below. The ESPE (BWS) is activated via terminal 63.

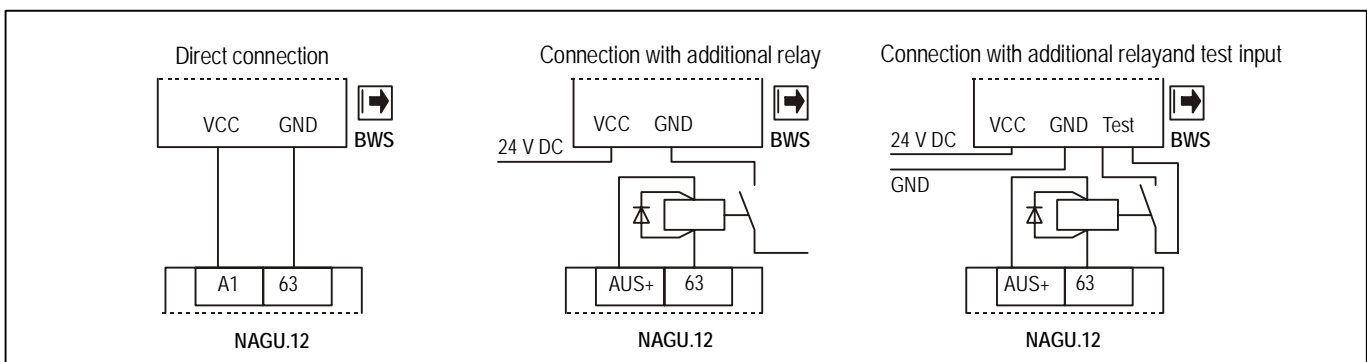

Direct power supply to the transmitter is only admissible if:

- The current consumption is smaller than 0.7 A and
- The peak current (<1s) is smaller than 4.5 A and
- The supply voltage does not fall below 21.6V at this moment in time.

If these values are exceeded, a supplementary relay (e.g. type RS-IR2 from riese electronic) must be interconnected.

WARNING

The use of external relays without a recovery diodes can result in damage to the muting controller. For this reason, always connect external relays with a recovery diode, e.g. type 1N4007.

Wiring safety outputs

The safety outputs must be electrically integrated in accordance with the safety category as specified by EN 954-1 and DIN EN 60204-1.

Terminals 14 and 24 are PNP safety solid-state outputs with cyclical testing. If the muting controller has started and the light beam of the BWS is unobstructed, the outputs switch and a voltage of 24 V DC is available. In the event of a fault, a residual voltage of appr. 9 V may still be active at the output.

Terminal 33 is an NPN safety solid-state output with cyclical testing. If the muting controller has started and the light beam of the BWS is unobstructed, the output switches to GND. In the deactivated status, a voltage of 24 V DC is active at the output. If there is a fault, a residual voltage of > 15 V may still be active at the output.

Expansion module RS-NAGX5 is provided in order to expand the safety outputs. For wiring details, see page 13.



To expand the safety outputs, relay with positive guided contacts are also admissible.

Depending on the safety category, the following wiring arrangements must be executed.

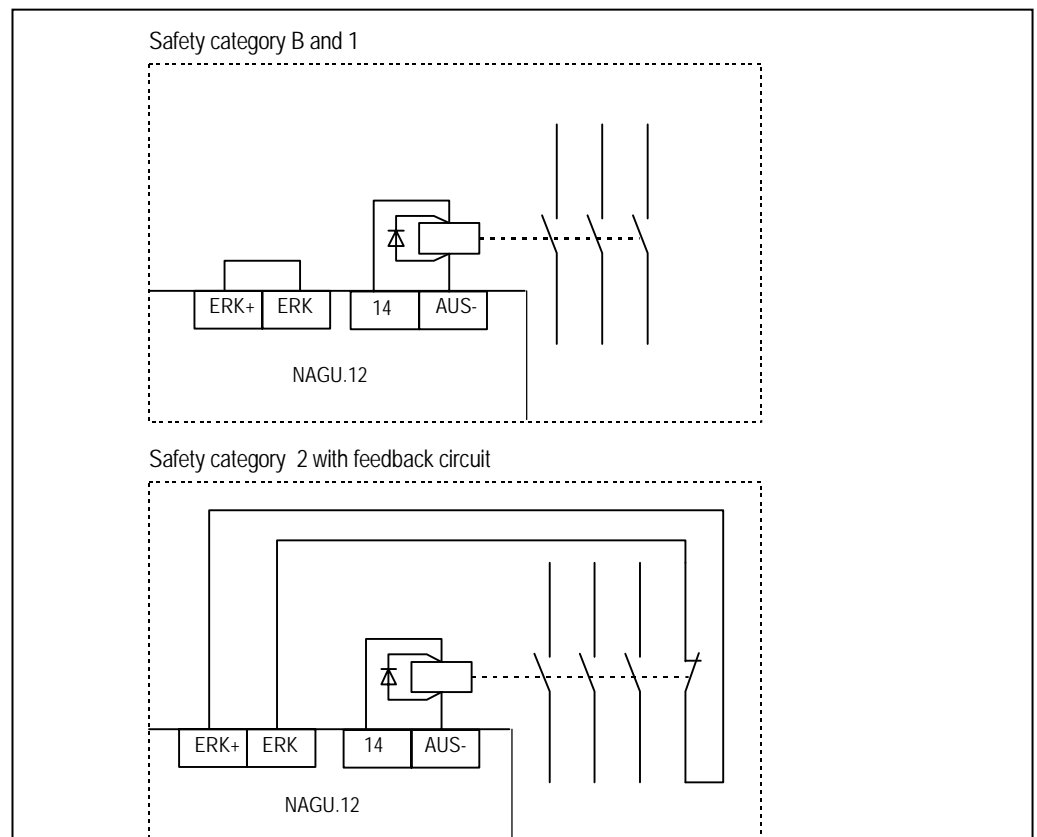

Always wire the coils of the external contactors with two adjacent cores of the same sheathed cable. For the two PNP outputs, use separate sheathed cables. A direct or indirect connection of the supply voltage to the safety outputs is not admissible.

⚠ WARNING

The use of external relays without a recovery diodes can result in damage to the muting controller. For this reason, always connect external relays with a recovery diode, e.g. type 1N4007.

Wiring feedback circuit

Using the feedback circuit, it is possible to monitor the statuses of these modules via the n.c. contact of an external contactor or of the expansion module, for example, the RS-NAGX5 from riese electronic.

☞ Connect the expansion module in accordance with the following circuit diagram.

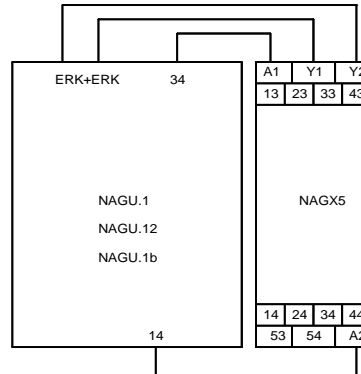

Usage as a controller for safety light barriers

Function

The muting controller RS-NAGU.12 can also be used as a controller for safety light barriers. In this case, the inputs for the muting sensors remain unconnected. The key-operated switch and muting lamp are not connected. A bridge must be inserted between the terminals 53 and AML. After the start, the outputs 14 and 24 switch to 24V, and 33 and 63 to ground. Other functions of the device are not affected.

Circuit diagram

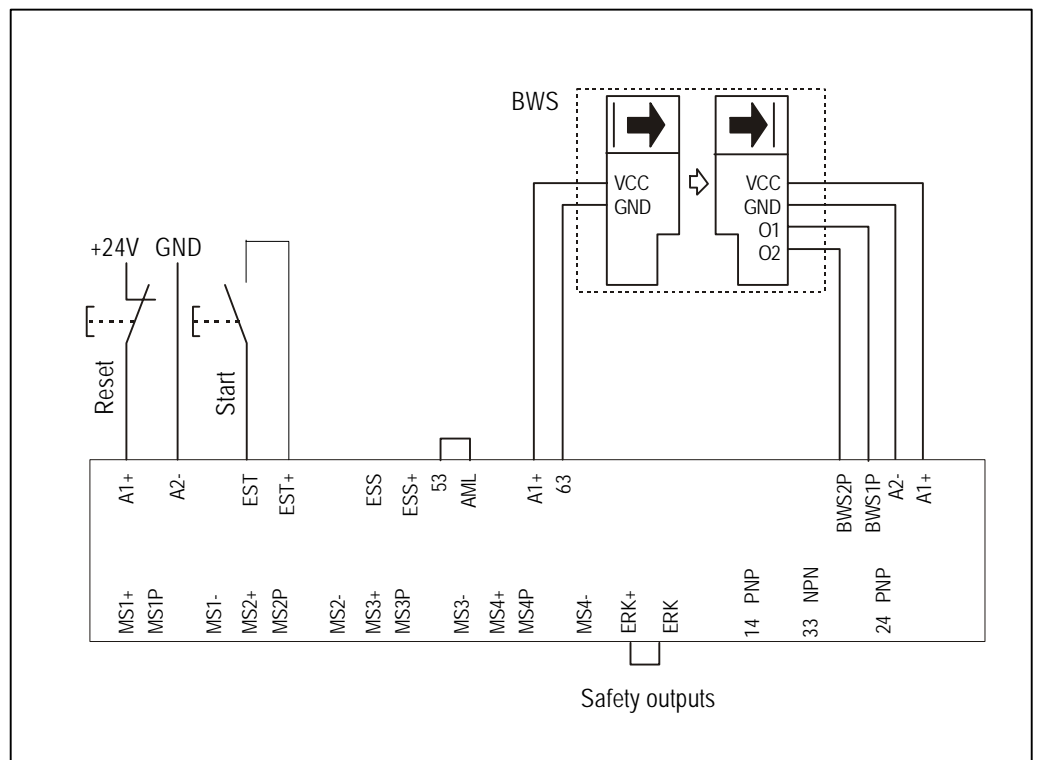

Maintenance and repair

The muting controller operates free of maintenance.



In the device RS-NAGU.12, the terminal blocks are not detachable.

Troubleshooting

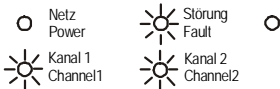

The muting controller is equipped with comprehensive troubleshooting functions. If an error is discovered, one or both LED's of channel 1 and channel 2 begin to flash. Thereby it's possible that under certain circumstances both LED's indicate different errors. The error code can be read off by the flashing LED's.

Example:

The channel 1 LED flashes 9 times (code 9) channel 2 LED flashes once (code 1)

⇒ channel 1 LED indicates the error "Muting lamp interrupted" and

⇒ channel 2 LED indicates the error "Inequality of the two channels".

At the same time, the fault LED lights.

Tip: If both LEDs are alight, the flashing code can be more easily read by covering over the other LED.

The next page show a list of all possible error codes with the relevant explanations, their possible causes and actions which can be initiated to remove the failure.



-
- 1. In case of an error, also check the supply voltage. At terminals A1+ and A2- 24 V DC must be available also after connecting all consumers to this supply voltage.**
 - 2. When switching devices or light barriers, the voltage must not drop below 21.6 V DC.**
-

Failure diagnostics

BC	Fault	Possible cause	What to do
1	Differences between the channels	- Only one channel detects an error	☞ Pay attention at the error code of the second channel
2	One of the channels does not work	- One channel defect	☞ Reset
3	Feedback circuit open	- N.C. contacts of external conductors are not wired - Bridge not wired	☞ Check wiring ☞ Check external conductors
4	Start button permanently activated	- Start button defect - Start switch is used instead of start button	☞ Check start button of short circuit ☞ Check start button (must be a button)
5	Key switch is activated during start	- Key switch activated - Key switch defect	☞ Reset ☞ Check key switch
6	ESPE receiver active during start	- Wiring error of the light barrier	☞ Check wiring; light barrier must be activated with output 63
7	Internal fault of the safety output	- Wiring error of safety outputs - Disturbances on the access line - Output defect	☞ Check wiring of safety outputs, pay attention to the wiring advice!
8	Internal fault of ESPE transmitter output	- Wiring error of safety light barrier - Disturbances on the access line - Output defect	☞ Check wiring of output 63, BWSE+, pay attention to the wiring advice!
9	Muting lamp disconnected	- Muting lamp defect - Muting lamp is missing - No bridge by application as controller for light barriers	☞ Check muting lamp and change if necessary
10	Two starts with key switch	- After the clearance of the light barrier the key switch was activated a second time	☞ Reset
11	Light barrier disconnected during start or time out on light barrier receiver	- Wiring error of safety light barrier - Optical Path is broken - Timeout reached	☞ Check wiring ☞ Check optical path ☞ Check technical data of the light barrier (start time, power consumption) ☞ Reduce current consumption with additional relay
12	Simultaneousness of muting sensors exceeded (3s)	- Wrong position of the muting sensors - Only one muting sensor was activated	☞ Check position of muting sensors, the material must activate both sensors within 3s ☞ Check wiring of muting sensors
13	Internal fault of muting lamp control	- Wiring error of the muting lamp - Muting lamp defect - terminal 53 is connected to GND - Output defect	☞ Check wiring of terminal 53 and ESS+ ☞ Check muting lamp
14	Muting time with key switch exceeded	- Manual muting timeout (10 min) reached	☞ Reset
15	Internal memory fault	- Disturbances on the access line - Internal error	☞ Reset; if BC comes again: check system on disturbances

Technical data

Electrical data

Supply voltage U_v	24 V DC
Voltage range	0,90 ...1,1 U_v
Ripple	$\leq 5\%$
Power consumption including all peripheral devices	appr. 60 W
Conductor connection	1 x 4,0 mm ² massive wire 2 x 1,5 mm ² strand with hull (Use 60/75°C copper wire only.)
Contact allocation	3 semiconductor safety outputs (short circuit protected 2xPNP, 1xNPN)
Switching voltage	24V DC
Delay off (light curtain)	< 6 ms
Input current	appr. 15 mA for each input
Simultaneousness of muting sensors	3 s
Muting time	max. 10 minutes by key switch, infinite during normal operation
Startup waiting time for safety light curtain receiver after 'Start'	max. 6 s
* Switching current output 14,24, 33	1,5 A permanent current (1 Output), up to 4,5 A peak current ($t < 1$ s, $U_v > 21,6$ V), 1 A permanent current (2 Outputs), 0,7 A permanent current (3 Outputs)
Output 63 (light barrier)	<0,7A (see "wiring ESPE")
* power supply muting sensors	Together max. 0,5A (24V DC)
* Muting lamp	24 V DC, max. 1 A
Total current	max. 2,5 A permanent current

Mechanical data

Housing material	Self extinguishing according to UL 94 V-0
Dimensions (WxHxD)	90x84x121 mm
Mounting	Snap mounting on universal mounting rail NS35 according to DIN EN 50022
Max. tightening torque	0,4 Nm (Tighten to 1 N.m. Overtorquing may cause enclosure breakage.)
Weight with terminals	Max. 465g
Storage	In dry areas

Environmental data

Environment temperature	-25°C ... +55°C
Humidity	Operation 75% (No dewing), Storage 85% (No dewing)
Terminal type	IP 20
Housing type	IP 40
Shock resistance	< 0,7 Nm
Vibration resistance	Frequency < 33 Hz, Amplitude < 0,35 mm

Certification

According to	EN ISO 13849-1
Achieved level/category	Performance Level d, Cat.2
MTTFd [years]	>100 "high"
DC	99% "high"
CCF	achieved

* the total current of all peripheral devices may not be larger than 2.2 A.

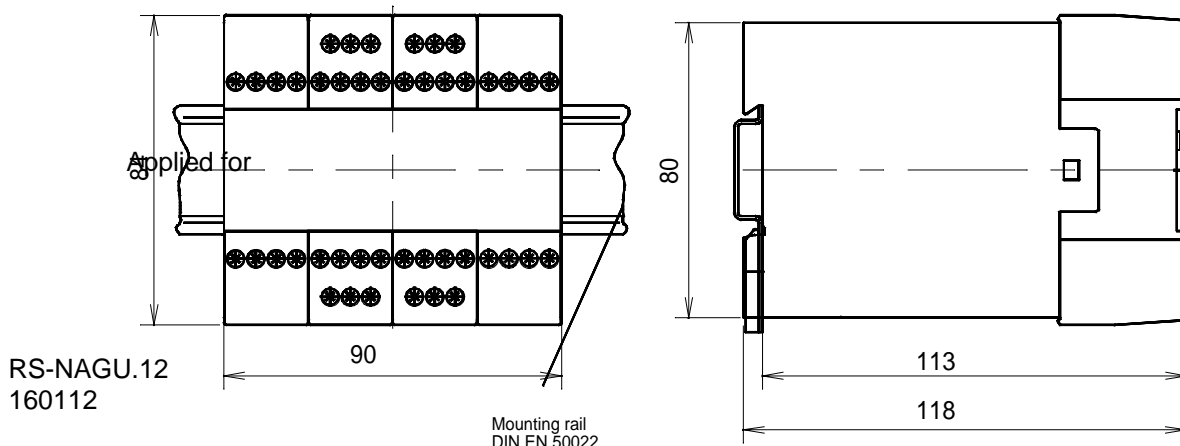

Ihr Kontakt zu riese electronic / your contact to riese electronic:

**Weitere Länder- / Gebiets – Vertretungen finden Sie auch im Internet:
all our representations can be found on our homepage:**

www.automation-safety.de/deutsch/index.htm

www.automation-safety.com/englisch/index.htm



Deutschland
Stammhaus: / Head office
Junghansstr. 16
D-72160 Horb am Neckar
Phone: +49 74 51 / 55 01 0
Fax: +49 74 51 / 55 01 70
info@riese-electronic.de
www.automation-safety.de
www.automation-safety.com

**Serviceadresse für ganz Europa /
servic adress for europe**

Niederlassung Ost Langenwolschendorf /
Langenwolschendorf branch
Dr.-Riese-Str. 1
D-07937 Langenwolschendorf
Phone: +49 3 66 28 / 72 5 0
Fax: +49 3 66 28 / 72 5 17
Email: info-lawo@automation-sicherheit.de

Exemplarisch ein Vertreter auf jedem Kontinent
Exemplary one representation on each continent

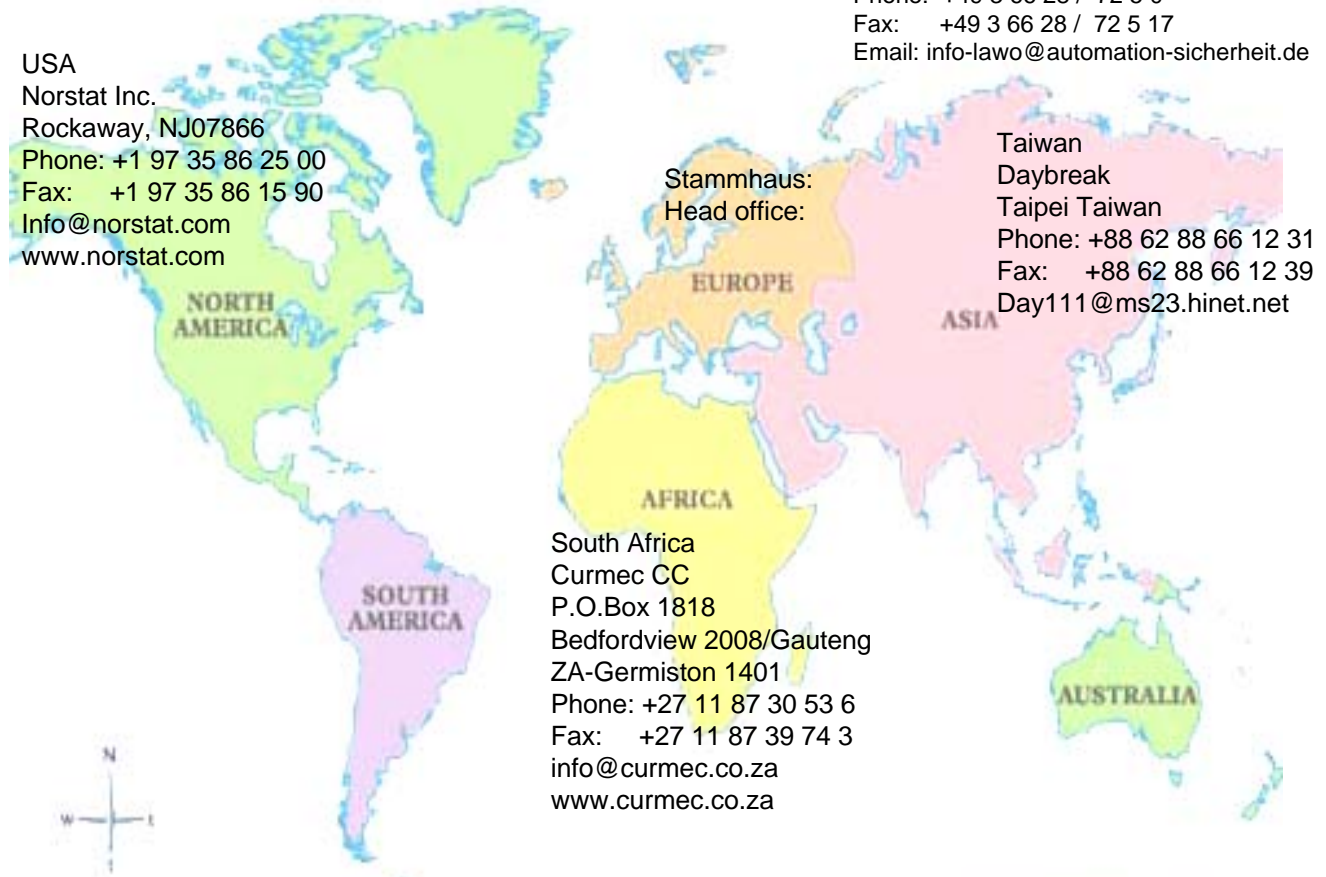

USA
Norstat Inc.
Rockaway, NJ07866
Phone: +1 97 35 86 25 00
Fax: +1 97 35 86 15 90
Info@norstat.com
www.norstat.com

**Stammhaus:
Head office:**

South Africa
Curmec CC
P.O.Box 1818
Bedfordview 2008/Gauteng
ZA-Germiston 1401
Phone: +27 11 87 30 53 6
Fax: +27 11 87 39 74 3
info@curmec.co.za
www.curmec.co.za

Taiwan
Daybreak
Taipei Taiwan
Phone: +88 62 88 66 12 31
Fax: +88 62 88 66 12 39
Day111@ms23.hinet.net

AFRICA

ASIA

AUSTRALIA

**Bitte fordern Sie zusätzlich Unterlagen an: /
Please ask for our additional information on:**

- Zeitrelais / time-delay relays
- Messrelais / measuring relays
- Sicherheitsrelais / safety relays
- Kundenspezifische Entwicklung und Fertigung elektronischer Baugruppen/
custom-made designs and the fabrication of electronic subassemblies
- Leitfaden für eine partnerschaftliche Elektronikfertigung / (only in German)

EG-Konformitätserklärung

EC Declaration of Conformity

RS-NAGU.1, RS-NAGU.12 und RS-NAGU.2f

Der Hersteller
The manufacturer
riese electronic gmbh,
Junghansstraße 16
D-72160 Horb am Neckar
Tel.: +49 (0) 74 51/5501-0

erklärt hiermit, dass folgendes Produkt
hereby declares that the following product

Produktbezeichnung
product name
Sicherheitsschaltgeräte für berührungslos wirkende Schutzeinrichtungen,
Mutingschaltgeräte
Safety controller for safety light curtains and light barriers, muting controller

Typenbezeichnung
type designation
RS-NAGU.1, RS-NAGU.12 und RS-NAGU.2f

allen einschlägigen Bestimmungen der Richtlinie **Maschinen (2006/42/EG)** entspricht.
Die unvollständige Maschine entspricht zusätzlich den Bestimmungen der Richtlinien **Elektrische Betriebsmittel (2006/95/EG)** und **Elektromagnetische Verträglichkeit (2004/108/EG)**.
Die Schutzziele der Niederspannungsrichtlinie wurden gemäß Anhang I, Nr. 1.5.1 der Richtlinie **Maschinen (2006/42/EG)** eingehalten.

*is conform to all relevant regulations of the directive Machinery (2006/42/EC).
The partly completed machinery conforms additionally the directives Low Voltage Directive (2006/95/EC) and Electromagnetic Compatibility (2004/108/EC).
The protection goals of the low voltage directive were maintained according to Appendix I, No. 1.5.1 of the directive Machinery (2006/42/EC).*

Folgende harmonisierte Normen und Richtlinien wurden angewandt:
The following harmonised standards were applied:

EN ISO 13849-1:2008	Sicherheit von Maschinen - Sicherheitsbezogene Teile von Steuerungen Teil 1: Allgemeine Gestaltungsgrundsätze	Safety of machinery - Safety-related parts of control systems - General principles for design
EN 60204-1:2006	Sicherheit von Maschinen- Elektrische Ausrüstung von Maschinen Teil 1: Allgemeine Anforderungen	Safety of machinery - Electrical equipment of machines - General requirements
Richtlinie 2006/42/EG Directive 2006/42/EC	Maschinen	Machinery
Richtlinie 2006/95/EG Directive 2006/95/EC	Elektrische Betriebsmittel	Low Voltage Directive

Die Maschine wurde von folgenden Prüfinstituten validiert:
The partly completed machine was validated by the following testing institutes:

TÜV NORD / Hannover
Am TÜV 1
30519 Hannover
Prüfbericht
certificate:
44 205 09 376463-009

Die unvollständige Maschine darf erst dann in Betrieb genommen werden, wenn festgestellt wurde, dass die Maschine in die die unvollständige Maschine eingebaut wird, den Bestimmungen der Richtlinie **Maschinen (2006/42/EG)** entspricht.
The partly completed machine must not be put into operation until the final machinery into which it is to be assembled has been declared in conformity with the regulation of the directive Machinery (2006/42/EC), where appropriate.

Die relevanten technischen Unterlagen wurden gemäß Anhang VII Teil B erstellt. Sie werden einzelstaatlichen Stellen auf begründetes Verlangen elektronisch oder postalisch übermittelt.
In response to a reasoned request by national authorities, relevant information on the partly completed machinery will be sent electronically or postal.

Dokumentationsbevollmächtigter ist:
Person that is authorized to compile the relevant technical documentation is:

Dipl. Ing. (TH) Helmut Geselle,
Tel.: +49 (0) 74 51/5501-0
Junghansstraße 16
D-72160 Horb am Neckar

Horb am Neckar,
9.5.11
Datum / date:

Unterschrift / signature - Oliver Riese, Geschäftsführer riese electronic gmbh / managing director